

NEW !

**MODERN VENTILATED FACADE
GLASS PANELS**

**CDESIGN
NORGPOL**



MODERN VENTILATED FACADE GLASS PANELS

■ Product description:

Type of glass: enamel

Facade material: safety glass
(toughened) in various RAL colours

■ System visualisation:

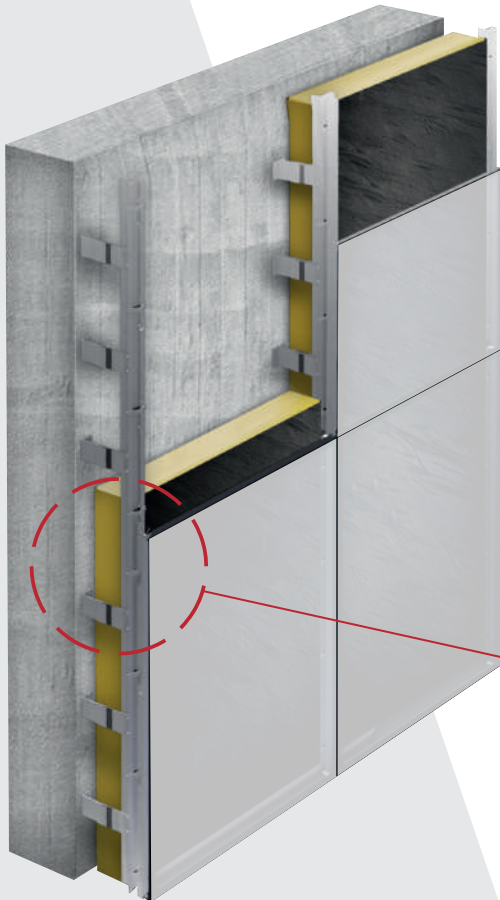

■ About the system:

The ventilated glass panel façade system is a modern solution that allows for an aesthetically pleasing and functional finish to a building.

The type and dimensions of consoles and profiles are selected on the basis of project documentation, depending on wind loads, structural and insulation requirements.

The system is used for low and medium-rise buildings (up to 19 m).

■ Advantages:

- Various divisions
- Various colours
- Easy to clean

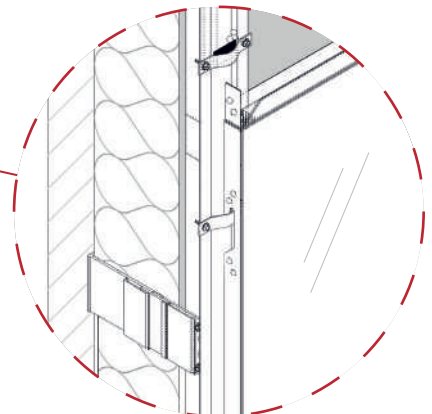



- This system is a robust solution for the design of ventilated facades.

The system ensures the durability and stability of the ventilated facade, guaranteeing an aesthetically pleasing and safe finish to the facade of any building.

■ Cross-section through the wall

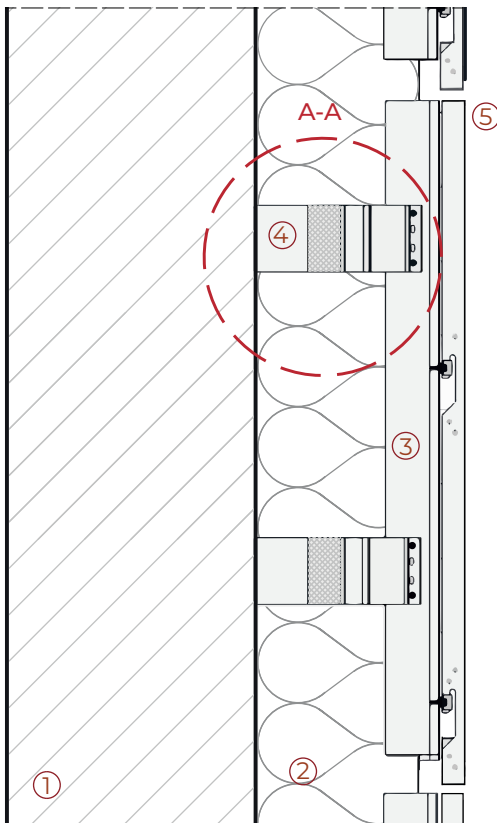

■ Vertical detail A-A

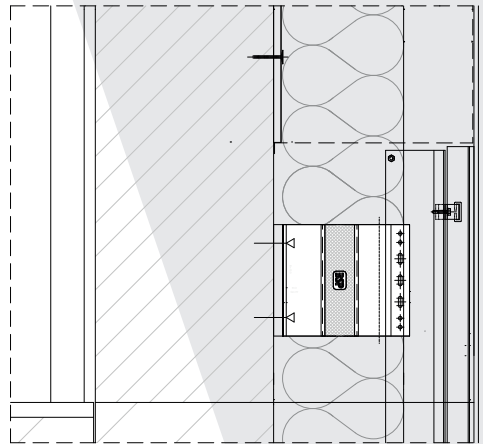

■ Horizontal detail

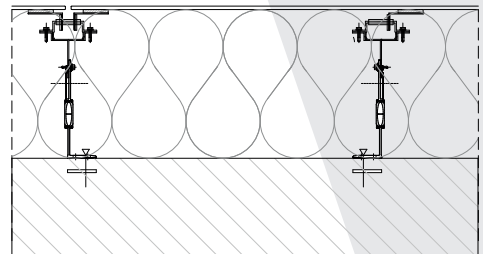

- ① Bearing wall
- ② Insulation
- ③ Facade construction
- ④ Mounting console
- ⑤ Glass panel



2024

MODERN VENTILATED FACADE GLASS PANELS

PROJECT



CZERWINSKA DESIGN

-  104 Baletowa Street, 02-867 Warsaw
-  +48 691 22 03 90
-  biuro@czerwinska-design.pl



czerwinska-design.pl

PRODUKCJA

NORGPOL
ROZWIĄZANIA DLA PRZEMYSŁU

CGLASS
OKUCIA DO SZKŁA

-  4a Przemysłowa Street, 08-500 Ryki



norgpol.pl

czerwinska-design.pl

